

Panel Mounting Hole Cutout

End View
Nut, Serrated Washer and Neoprene removed.

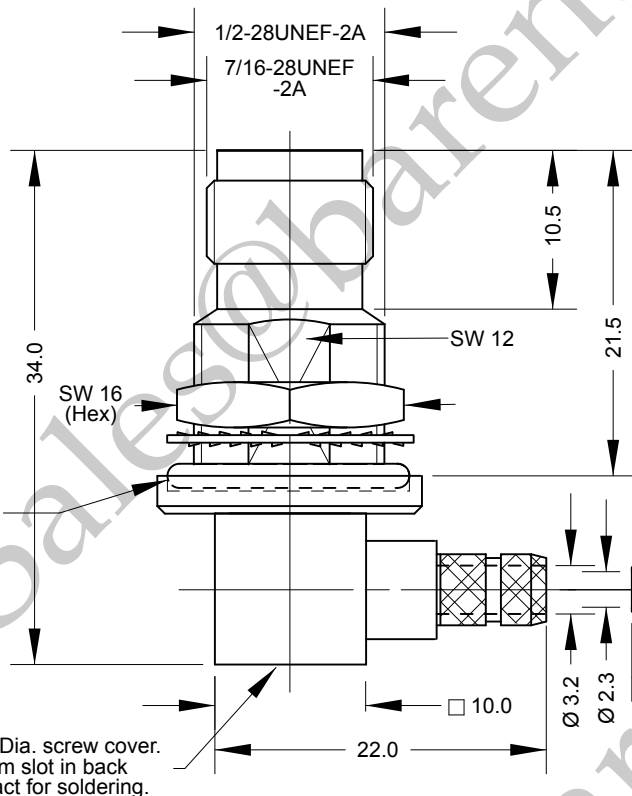
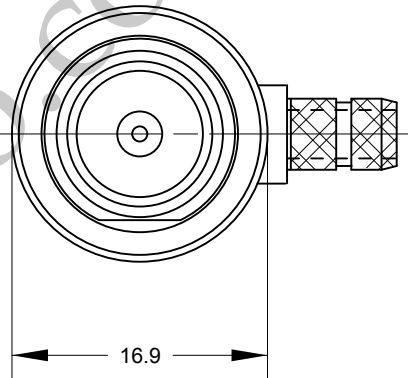

Note.
Supplied with heatshrink for crimp ferrule
Crimping Details
Crimp Ferrule Hex 0.213" (5.41mm)
Crimp Tool Order Code:-
180455, 180456 & 180458

Red neoprene ring seal

Plastic Tube

Cable : RG174, RG188, RG316 & Equivalents

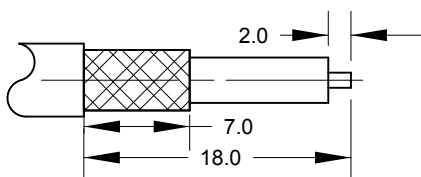

Cable Preparation

Cable Construction Specifications

	RG174	RG188	RG316
Inner Conductor	0.48mm	0.51mm	0.53mm
Dielectric	1.52mm	1.52mm	1.53mm
Overall Braid	1.98mm	2.06mm	1.98mm
Jacket	2.54mm	2.79mm	2.50mm

6	Ferrule	Phosphor Bronze	1	CuSnZn3
5	Nut	Brass	1	CuSnZn3
4	Crimp Ferrule	Brass	1	CuSnZn3
3	Shell / Body	Brass	1	CuSnZn3
2	Insulator	PTFE / Teflon	1	
1	Contact Socket	Phosphor Bronze	1	GOLD
CODE	DESCRIPTION	MATERIAL	QTY	FINISH

Barenco Ltd

Unit 14 Winterbeck Ind. Est. Orston Lane, Bottesford, Nottinghamshire NG13 0AU. Tel. 0(44)1949 860400
Email.Sales@barenco.co.uk. Web.www.barenco.co.uk

BARENCO Ltd

DRAWN Name	BPG	TNC elbow bulkhead socket crimp for RG174, RG188 & RG316	
Dimensions: mm		SIZE	DWG NUMBER
Date	31/12/2020	A4	165335S
Last Rev.		REV -	SHEET 1 OF 1
SCALE 1 : 0.5			