

Panel Mounting Hole Cutout

End View
Nut, Serrated Washer and Neoprene removed.

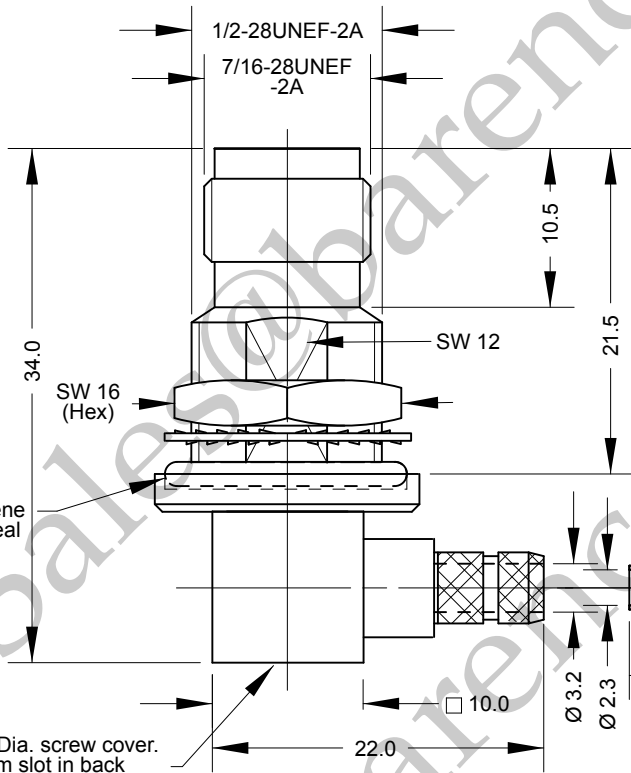
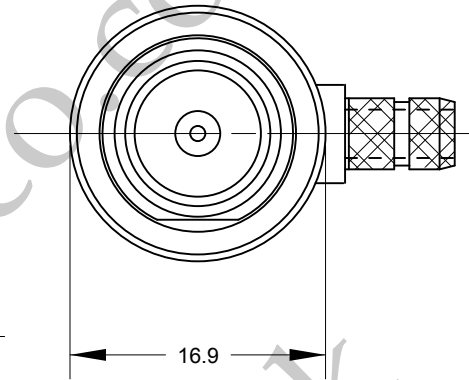

Note.
Supplied with heatshrink for crimp ferrule

Crimping Details

Crimp Ferrule Hex 0.213" (5.41mm)

Crimp Tool Order Code:-

180455, 180456 & 180458

7.75mm Dia. screw cover.
1.1mm slot in back
of contact for soldering.

Cable : RG178, RG196 & Equivalents

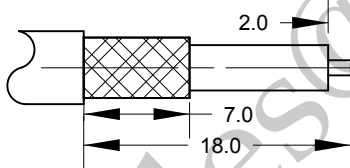

Cable Preparation

Cable Construction Specifications

	RG178	RG196
Inner Conductor	0.30mm	0.28mm
Dielectric	0.86mm	0.89mm
Overall Braid	1.30mm	1.37mm
Jacket	1.80mm	1.94mm

6	Ferrule	Phosphor Bronze	1	CuSnZn3
5	Nut	Brass	1	CuSnZn3
4	Crimp Ferrule	Brass	1	CuSnZn3
3	Shell / Body	Brass	1	CuSnZn3
2	Insulator	PTFE / Teflon	1	
1	Contact Socket	Phosphor Bronze	1	GOLD
CODE	DESCRIPTION	MATERIAL	QTY	FINISH

BARENCO Ltd

Barenco Ltd

Unit 14 Winterbeck Ind. Est. Orston Lane, Bottesford,
Nottinghamshire NG13 0AU. Tel. 0(44)1949 860400
Email.Sales@barenco.co.uk. Web.www.barenco.co.uk

DRAWN Name BPG

Dimensions: mm

Date 31/12/2020

Last Rev.

SCALE 1 : 0.5

TNC elbow bulkhead
socket crimp for
RG178 & RG196

SIZE A4 DWG NUMBER 165335T

REV - SHEET 1 OF 1